

Static VAR-Compensators for stabilizing traction and transmission systems in South Africa

H. Pesch, S. Ranade, M. Schubert, P. Sieber

AEG Germany

P.V. Goosen, R.D. McFarlane

ESCOM, South Africa

Summary

Five static VAR-compensators -50/250 MVar are being installed in the South African 400 kV System of ESCOM, and further six -10/35 MVar compensators in regional 132 kV systems. These compensators, supplied by AEG-TELEFUNKEN, are of the TCR/C_{fix}-type.

The paper refers to design criteria of the overall concept, the thyristor valve arrangement and the Layout of the plants. Experience of commissioning and initial commercial operation of the first two 132 kV compensators is also presented including harmonic instability problems at the second harmonic.

Introduction

System utilizers have taken the chance to improve the transmission capability of their system not by extension, but by improving the transmission quality of the existing network. This can be achieved by

- stabilizing the system voltage,
- balancing of system voltage,
- limiting of over voltages and voltage collapses,
- damping of oscillations,
- reduction of reactive power flow.

Static VAR compensators can fulfil these requirements due to their continuous and fast controllability.

System Configuration

Transmission problems in the extensive 400 kV system in South Africa will be solved with the installation of five static compensators (FIG. 1):

- 2 x -50/250 MVar in PERSEUS
- 2 x -50/250 MVar in HYDRA
- 1 x -50/250 MVar in POSEIDON.

For similar reasons regional 132 kV sections will be improved by installing six -10/35 MVar compensators, two of them in the Northern Transvaal area and four in the Eastern Cape Province

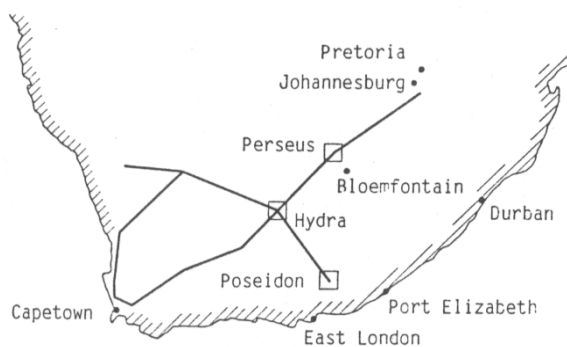

Fig. 1 Southern region of the 400-kV-network in South Africa

Design and Construction

Basic Concept

All compensators, supplied and installed by AEG-TELEFUNKEN, are of the TCR/C_{fix}-type with the capacitor banks extended to tuned 3rd and combined 5/7th harmonic filters. This configuration was chosen because of its decisive advantages in comparison with other compensator types:

- simple and robust arrangement
- high operation safety and reliability
- steady MVar control over the total range
- fast control response
- single or 3-phase control characteristic
- low losses
- low investment cost

The power circuit (FIG. 2) was designed with a star / star transformer, star points solidly grounded, and delta

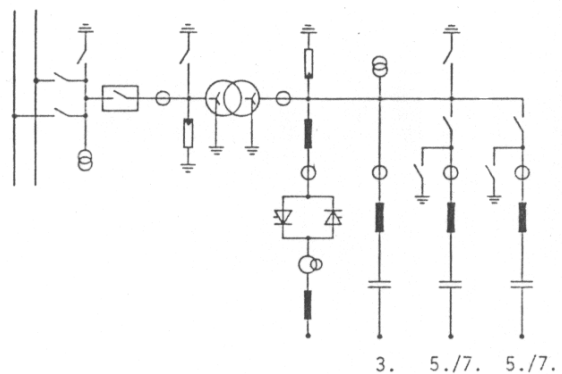

Fig 2 Single line diagram of 400-kV-compensators

configuration of the TCR and the filter banks.

Main Data (TABLE 1)

	400 kV compensator	132 kV compensator
main data:		
rating	-50/250 MVAR	-10/35 MVar
frequency	50 Hz	50 Hz
secondary voltage BIL in secondary circuit (except thyristor valves)	30 kV 200 kV	5,1 kV 60 kV
TCR rating	244 MVar	47 MVar
nominal TCR current	2980 A	2950 A
installed capacitive power subdivided into filter banks	410 MVar -2x155 MVar for 270 Hz -1x100 MVar for 150 Hz	64 MVar -1x43 MVar for 270 Hz -1x21 MVar for 150 Hz
thyristor valve data:		
modules per valve	4	1
structures per valve	2	1/3
thyristors per module	2x7	2x6
thyristor redundancy	8 %	20 %
max. contin. valve current	3100 A	3200 A
BIL	83 kV	15 kV
thyristor pellet diameter	100 mm	100 mm
thyristor blocking capability	4.2 kV	4.0 kV

The high current of about 3000 A and the relatively low voltage of the compensator circuit are based on the use of 100 mm thyristors. The low number of series connected thyristors resulted in low valve cost.

Originally, the compensators were designed for the full capacitive and inductive load at nominal voltage, but this was later on changed to full capacitive load at nominal to lowest System voltage and full inductive load at nominal to maximum system voltage (in case of the -10/35 MVar compensators). By disconnecting filter banks the inductive range of the 400 kV compensators can be extended from -50 to -200 MVar.

Due to the 6-pulse arrangement of the TCR the capacitance is used as filter and subdivided into a 3rd and combined 5/7th filter, tuned at 270 Hz. The 3rd filter is rated to match the full 3rd harmonic current only in one branch of the TCR delta.

Thyristor Valves

The thyristor valve structure MEGASEMI used for static compensators was developed from the valve concept of AEG-TELEFUNKEN for HVDC converters, so that its essential properties are:

- modular assembly,
- indoor installation,
- deionised water cooling,
- air insulation,
- opto-electronic signal transmission,
- de-coupling of auxiliary energy on thyristor potential,
- continuous thyristor monitoring and fault annunciation on ground potential.

Some thyristor valve data are listed in TABLE 1, the valve arrangements are shown in Fig 3 (thyristor valve structures).

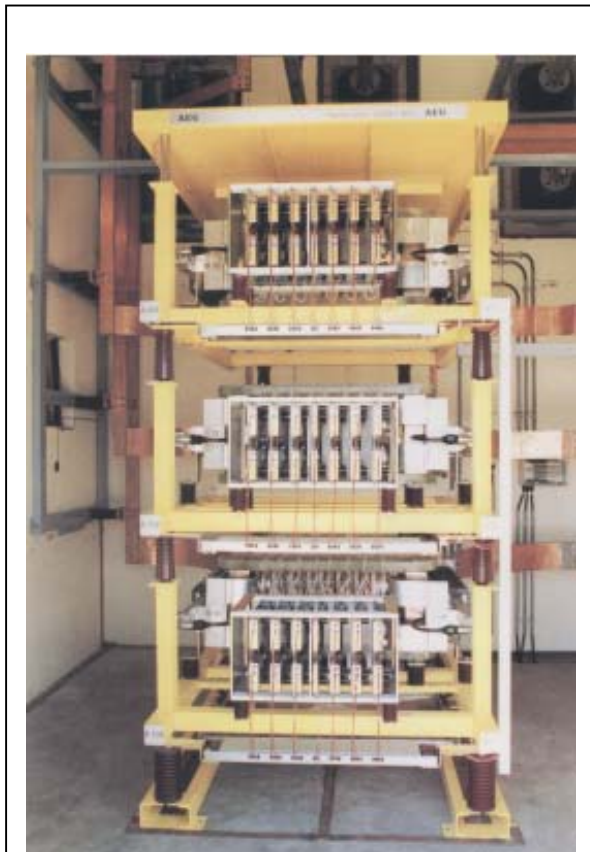

Fig 3 a) for 45 MVar of 132 kV compensator

Besides the normal routine tests the following type tests were conducted successfully:

a) on the valve structure:

- switching surge test with and without B0D- firing
- lightning surge test
- AC voltage withstand test (50 Hz) with PD-measurement

b) on the thyristor module:

- heat run with nominal operation data, determination of losses
- functional test of thyristor protection on thyristor level
- recording of current and voltage traces, measurement of extinction overshoots
- AC voltage withstand test (50 Hz)
- periodical and non-periodical ignition test

Control and Protection

Each branch of the TCR-delta has its own independent control circuit. Thus the TCR can react asymmetrically or with a superimposed common reference symmetrically. This feature was chosen to achieve both voltage balance and voltage level control.

The concept comprises:

- the primary voltage control with adjustable reference
- the TCR-current limiting control, which prevents the valves from being overloaded
- the secondary voltage limiting control for the over voltage protection of the capacitors
- the DC current control which sets the DC current in the TCR to zero and thus prevents pre-magnetizing of the transformer.

Start up and shutdown sequences are performed by a microprocessor. Ten milliseconds after energizing the transformer the thyristor firing is released at a fixed reference value of 0 MVar, thus avoiding an additional load shock during the inrush event. Same periods later the automatic controls take over.

The protection system comprises conventional earth fault detections, transformer and filter protection and the TCR protection, part of which is taken care of by the relevant control circuits. The probability of a full valve short-circuit is reduced by subdividing the reactors into two halves. Nevertheless, the valves will be blocked at four times the rated current and the circuit breaker will be tripped. The TCR protection is fully redundant and can be tested during operation.



Fig 3 b) for 250 MVar of 400 kV compensator

Layout

With the relatively low voltages a compact layout could be chosen, however, taking into account the necessary magnetic clearances of the air core reactors. A simple and clear conductor arrangement in the bus bar area, low space requirement, less heating due to eddy currents at the reactor terminals, and lower cost were the criteria decisive for the choice of channel conductors instead of tubular conductors. FIG. 4 shows the layout of a 400 kV compensator, while an Impression of a 132 kV compensator is conveyed by FIG. 5.

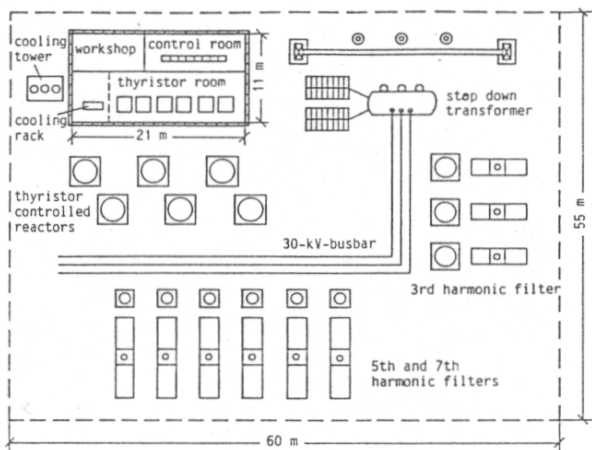

Fig 4 Layout of a static compensator for 400 kV, -50/250 MVar



Fig 5 132 kV compensator plant

The space requirements are:

	400 kV compensator	132 kV compensator
outdoor plant	3070 m ²	940 m ²
building	230 m ²	110 m ²
total	3300 m ²	1050 m ²

Simulator Studies

Extensive studies in three phase mode were conducted on the parity simulator of the FGH at Mannheim-Rheinau for both the regional 132-kV-system with two compensators as well as for the southern 400-kV-system with three compensators at

various locations. Since the tests with the 400-kV-system are not yet complete, the report refers to the 132 kV test only.

The tests had the objectives

- a) to check the control performance of the compensator,
- b) to pre-adjust the actual control circuits matching system stability conditions,
- c) to determine maximum over voltages,
- d) to investigate the interaction between two compensators,
- e) to study switch on/off phenomena,
- f) to discover possible harmonic resonances.

A lot of dynamic occurrences under variable network conditions were investigated. No excessive over voltages were recorded and no 50 Hz or harmonic resonances were found. This was different from later experience during commissioning of the first compensator when strong second harmonic instabilities were found. The reason must be seen in the difficulty to represent real harmonic impedances in the model correctly.

A compromise had to be found for the pre-adjustments, i.e. to make the response fast for suppression of over voltages, but to slow it down in order to prevent load oscillations after transients. FIG. 6 shows the response of two compensators to a single and a 3-phase fault in the system, where both are acting independently without influencing each other.

Commissioning

The two 132 kV compensators in Northern Transvaal were the first to start commercial operation, i.e. in April and July, 1983. High voltage commissioning was conducted in the following steps:

- g) energizing the transformer with its secondary terminals open
- h) energizing the compensator without filters
 - operation at low currents
 - switch on/off sequences
 - measurement of harmonics
 - pre-calibration of control circuits at low loads
- i) energizing of the compensator with single filters
- j) energizing the complete compensator investigation of inrush events
- k) steady-state operation performance
 - repetition of previous tests
 - power adjustment over the total range
 - optimising control characteristic
 - temperature measurements
 - load recordings versus system voltage
 - harmonic analyses
- l) dynamic operation performance
 - energizing another transformer on the same bus bar
 - switching of inductive and capacitive loads in the system
 - single and 3-phase switching of lines in the system

On first energizing of the complete compensator a 2nd harmonic instability was observed (FIG. 7a). This is caused by the inrush event of the transformer, when the 2nd harmonic current, generated due to the Saturation effect, enters the impedance configuration of System, transformer and filters and meets resonance conditions. Then it is amplified so that the

secondary transformer voltage is heavily distorted. As soon as the thyristor valves are fired a correspondingly distorted current is generated by the TCR containing a DC component. This again supports the premagnetizing effect of the transformer maintaining the voltage distortion.

As we have observed over several seconds this event with a strong 2nd harmonic can become stabilized. Various tests to improve this performance by modifying the controls only were not satisfactory. However with the additional installation of a tuned 2nd harmonic filter the problem could be solved for any practical network configuration, as can be taken from FIG. 7b).

Conclusion

By installing static VAR-compensators Escom intends to improve the transmission quality and to obviate future difficulties which could be caused by e.g. subsynchronous oscillations in the 400-kV-system or unsymmetrical traction loads in the 132 kV networks.

AEG-TELEFUNKEN has successfully commissioned two 132 kV compensators. The operation experiences of the first five and three months respectively are excellent. Two 400 kV compensators are already erected and shall be placed in commercial operation by end 1983. The time schedule for the further seven compensator plants runs until mid of 1985.

$V_{RW,WB,BR}$	-	primary bus bar phase to phase voltages
$I_{RW,WB,BR}$	-	TCR delta branch currents
$V_{R,W,B}$	-	primary bus bar phase to ground voltages
$V_{S-RW,WB,BR}$	-	secondary bus bar phase to phase voltages
$I_{p-R,W,B}$	-	primary phase currents

Legend to Fig. 6 and 7

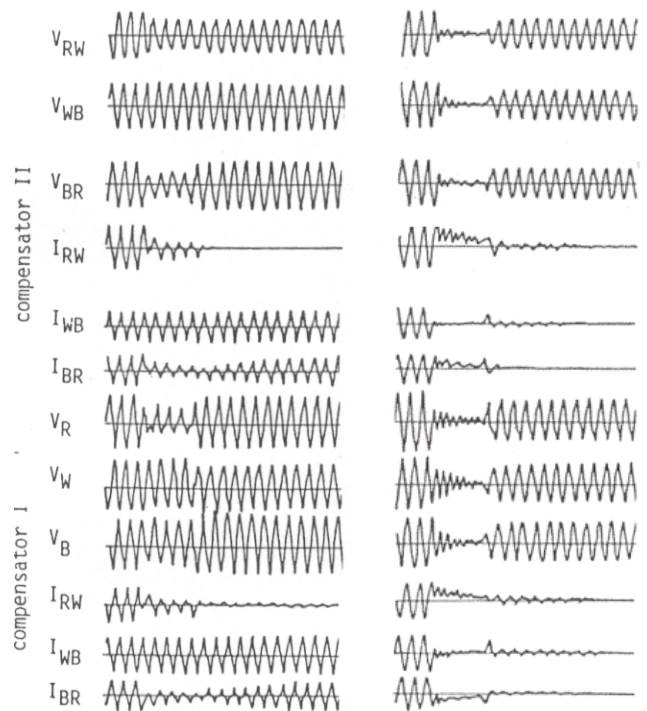

a) single phase fault in the system b) 3-phase fault in the system

Fig 6 Simulator tests with two 132 kV compensators

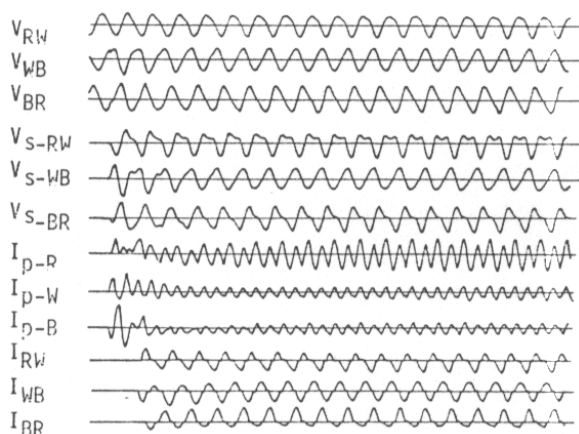

a) without 2nd harmonic filter

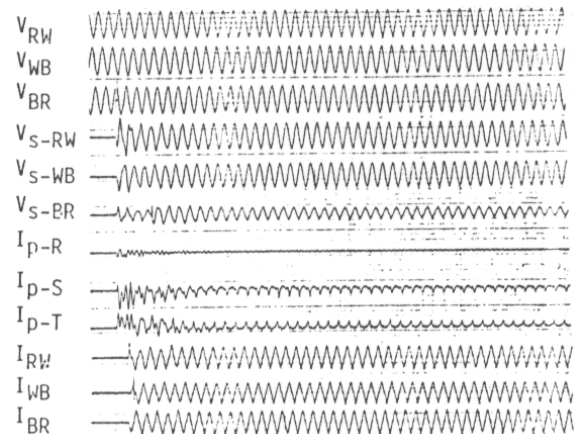

b) with 2nd harmonic filter

Fig 7 Switching on of 132 kV compensator during commissioning

Your Partner

AEG
Industrial Engineering GmbH

International Berlin Office
Hohenzollerndamm 152
14199 Berlin, Germany

Tel.: +49(30)82099490
Fax: +49(30)82099499
E-Mail: aeg@aeg-ibo.com
Web: www.aeg-ibo.com

AEG Industries at Hohenzollerndamm area is the communication centre
for current and former AEG factories world wide and is responsible for plant engineering



We take care of your Power Quality